

REVISIONS				
ZONE	REV	DESCRIPTION	DATE	APPROVED

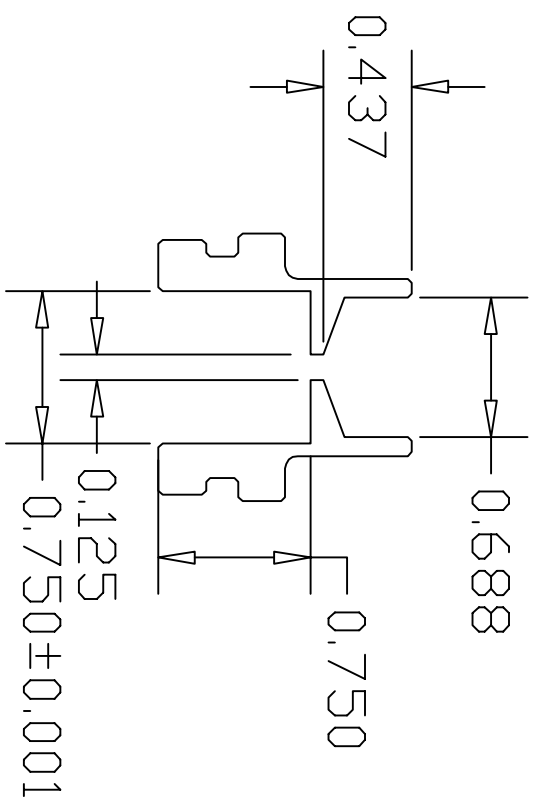

Cut this dimension undersize and knurl to within the stated tolerance.

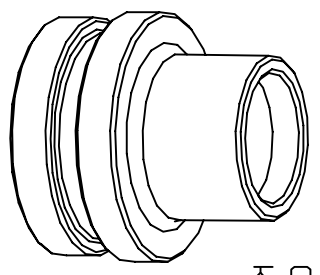
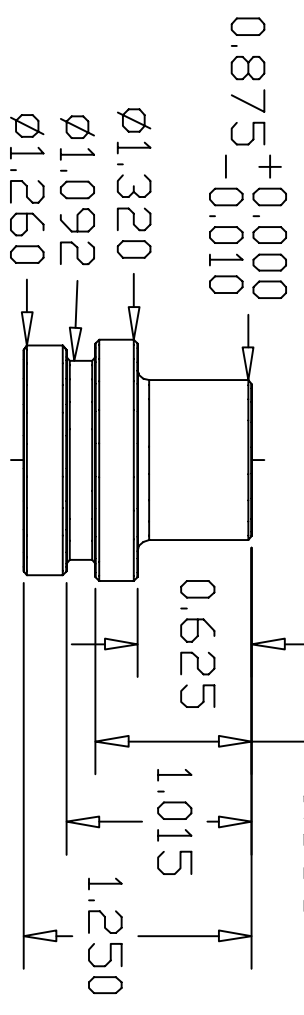

Coarse diamond knurl upper 1/2"

Dimensions are inches and are +-.0005" unless noted.

Material is 6061 aluminum Type II or III anodized finish is optional

Loki Research, LLC

Delay Bulkhead for 38mm

Jeff Taylor

SIZE	FSCM NO.	DWG NO.	REV
SCALE	SHEET		